

# TS-5000 Trailer Stabilizer

Stabilize the nose of trailers to minimize loading dock accidents when loading and unloading spotted trailers.



Trailer tip-over (nose roll)



Trailer up-ending (nose drop)

The wide top plate and twin vertical supports will absorb momentum caused from landing gear collapse and help to minimize the trailer nose from rolling or dropping.

Provides heavy-duty support when the trailer stabilizer is positioned snug under a spotted semi-trailer at the loading dock. The TS-5000 Trailer Stabilizer helps make loading docks safer.

## Extra support for heavy and uneven loads

- › When fork trucks load at the front of trailers, the trailer can become nose heavy and tip
- › Uneven and heavy loads at the front of trailers can cause the trailer nose to tip
- › The TS-5000 Trailer Stabilizer can help prevent trailer up-ending and trailer tip-over

## Helps prevent accidents due to landing gear collapse

- › Seldom used or rusted landing gear may collapse under extreme weight conditions
- › With the TS-5000 Trailer Stabilizer, the trailer remains supported and helps to minimize this potential danger

## Easy operation

- › Always ready-to-use crank
- › Ergonomic positioning handles with multiple grip points
- › Handles act as a stop to prevent unit from getting pushed too far under trailer
- › Unit does not need to be tilted for proper placement
- › (3) 13" rubber tires make the unit easy to move and operate
- › Gear mechanism can be released even if there is downward pressure from the trailer load
- › Optional communication flag identifies when unit is properly positioned



# Specifications/Survey

Date \_\_\_\_\_  
 Company Name \_\_\_\_\_  
 Address \_\_\_\_\_  
 City \_\_\_\_\_  
 State \_\_\_\_\_ Zip Code \_\_\_\_\_  
 Representative \_\_\_\_\_  
 Salesperson \_\_\_\_\_  
 Quantity \_\_\_\_\_ Signature \_\_\_\_\_

## TS-5000 TRAILER STABILIZER FEATURES

- » Static load capacity: Rated for 70 tons static load (140,000 lbs/63,500 kg)
- » Minimum height retracted: 40" (1016 mm)
- » Maximum height extended: 56" (1422 mm)
- » Unit can be field adjusted to accommodate most commonly used trailer heights
- » Crank turns per inch of travel: 2
- » Weight: 435 lbs (198 kg)
- » 5.5" (140 mm) long positioning handles. Ergonomically designed for multiple grip points.
- » Multiple units can nest for storage
- » 3-year warranty
- » This trailer safety system meets or exceeds requirements of:
  - OSHA Regulation 1910.178
  - TTMA Technical Bulletin No. 57
  - AIAG 3.3.6 Shipping and Receiving Handbook

## DIMENSIONS

- » Top plate (1): 12" x 66" (304 mm x 1676 mm)
- » Base plates (2): 10" x 16" each (254 mm x 406 mm)
- » Tires (3): 13" (330 mm)
- » Operating range: 40" to 56" (1016 mm to 1422 mm)

## CONSIDERATIONS

1. Measure height of all trailers from ground level to nose (DIM 'A').
2. Select the tallest available height that is less than smallest measured Dim 'A'

## SELECT WORKING RANGE: (DIM 'A')

- 46.75" to 56" (1187 mm to 1422 mm)
- 44.50" to 56" (1130 mm to 1422 mm)
- 42.25" to 56" (1073 mm to 1422 mm)
- 40" to 56" (1016 mm to 1422 mm)

*Note: Select tallest working range that will accommodate most trailers. Working range can be field adjusted to position under shorter trailers, or raised for taller trailers. Selecting the proper working range will minimize crank turns needed for snug placement and removal from under the trailer.*

## COMMUNICATION FLAG

- No
- Yes

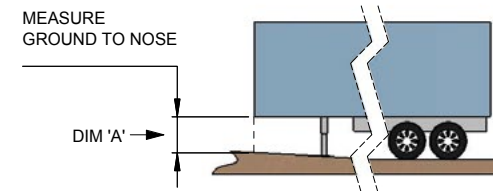
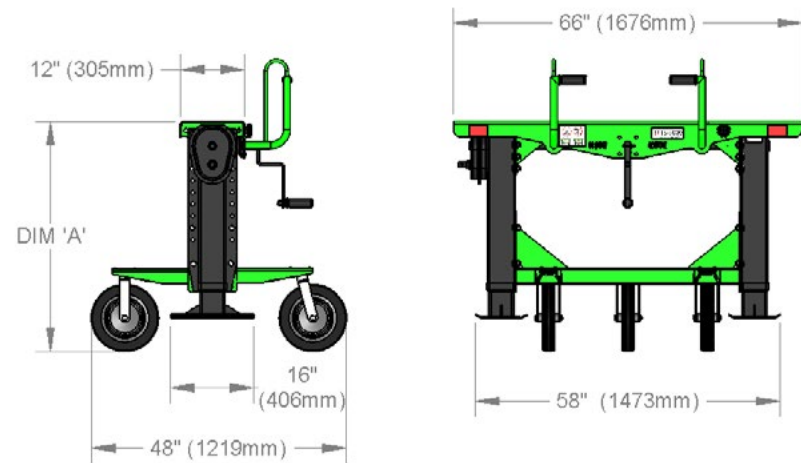

TS-5000 Trailer Stabilizers nest together for storage



A19TS5SS0718H1

8900 North Arbon Drive  
 Milwaukee, WI 53223, USA

P 414-355-2600 (800-456-0600)

F 414-355-9248

Rite-Hite® is a trademark of Rite-Hite Holding Corporation. Rite-Hite products are covered by one or more U.S. patents with other U.S. and foreign patents pending. The information herein is provided as a general reference only regarding the use of the applicable products. The specifications stated here are subject to change.

[www.RiteHite.com](http://www.RiteHite.com)